

COMPRESSION SPRINGS SPECIFICATION FORM

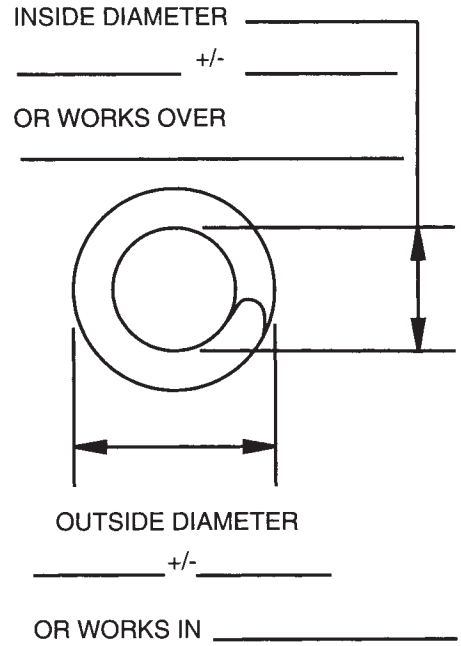
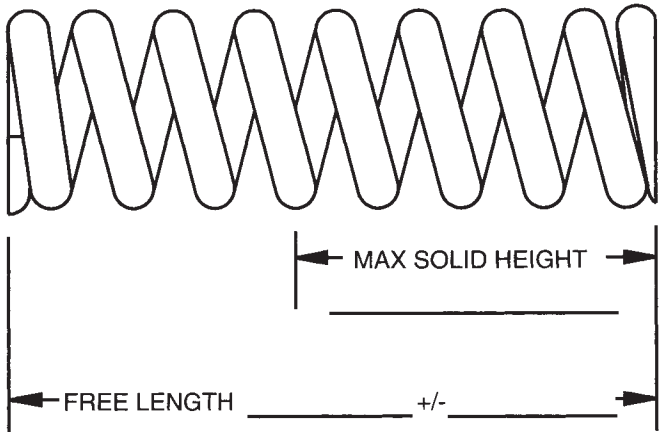
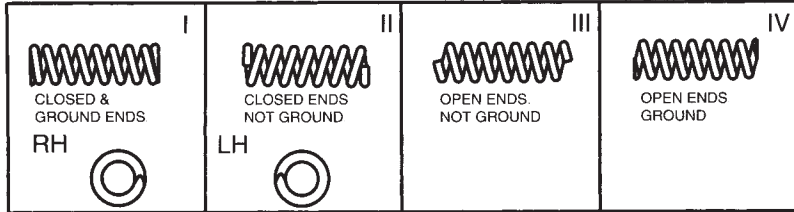

INDICATE UNITS OF MEASURE (IN & LB), (MM & KG)

1. MATERIAL _____
2. WIRE DIA. _____
3. DIRECTION OF WIND OPT, LH, RH
4. STYLE OF END I, II, III, IV
5. SQUARENESS _____
6. RATE _____ +/- _____ BETWEEN _____ & _____
7. LOAD 1 _____ +/- _____ @ _____
8. LOAD 2 _____ +/- _____ @ _____
9. No. OF ACTIVE COILS _____
10. TOTAL No. OF COILS _____
11. FINISH _____
12. FREQUENCY OF COMPRESSION _____ CYCLES/SEC.
AND WORKING RANGE _____ IN. TO _____ IN. OF LENGTH
13. OPERATING TEMP. _____ °F
14. OTHER: _____

COMPANY:
ADDRESS:
CITY: _____ ST: _____ ZIP: _____
CONTACT:
PHONE:
FAX:
EMAIL:
QUANTITIES TO BE QUOTED:
END USE OR APPLICATION: